



# P7-M2 SSD (solid-state drive) Inject/Eject Mechanism

## M.2 Form Factor

- Intuitive operation with push to close and press button to release function
- Toolless installation with rotate to locked and unlocked position
- Colour button to your industry standard
- Special rib design on housing to avoid wobbling

### Material and Finish

Button: PC/ABS

Housing: Nylon

### Performance Details

Flammability rating: UL-94-V2

Allow  $\pm 10\%$  tolerance of your PC board thickness

### Installation Notes

See page

### Part Number

See table

### Module Ejector

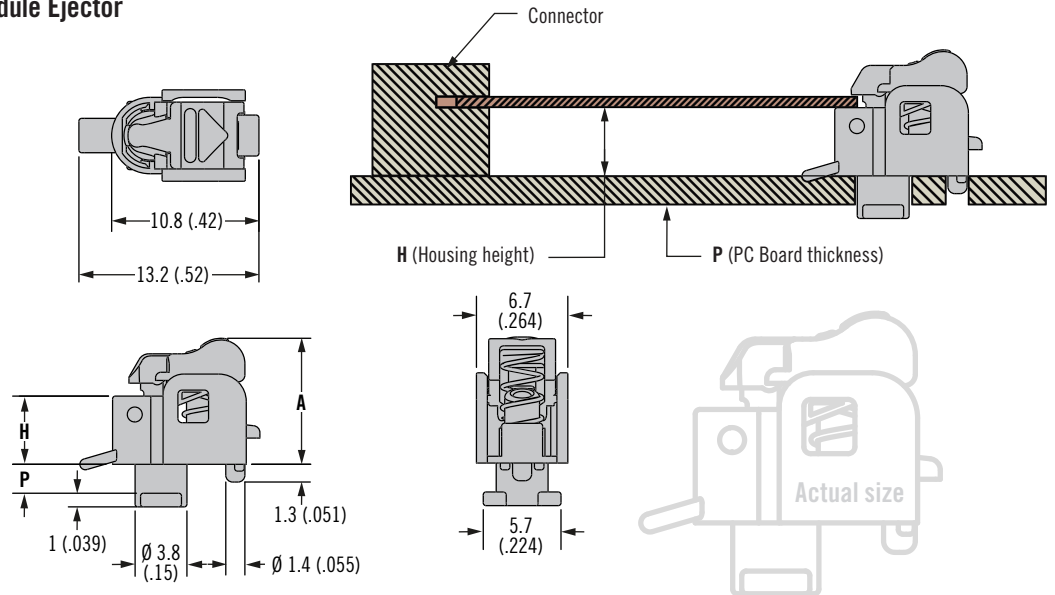

**To Install:** Insert latch through keyhole and rotate 90° until locking tab enters hole.

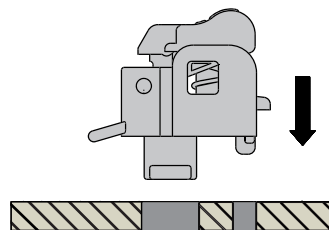

M2 Board: Notch to lock board to latch.

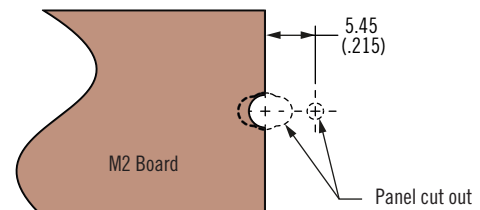

PC Board: Prepare keyhole and locking tab hole.

**To Remove:** Lift locking tab and rotate latch 90°

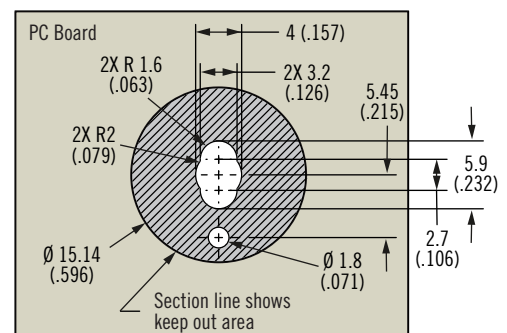
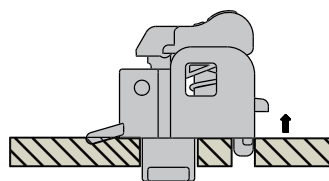

Part Number	Housing Height (H)	PC Board Thickness (P)	Height (A)
P7-M2-24-160-008	2.45 (.096)	1.6 (.063)	6.7 (.263)
P7-M2-24-210-008	2.45 (.096)	2.1 (.082)	6.7 (.263)
P7-M2-24-240-008	2.45 (.096)	2.36 (.093)	6.7 (.263)
P7-M2-50-193-008	5 (.196)	1.93 (.076)	9.24 (.363)
P7-M2-50-236-008	5 (.196)	2.36 (.093)	9.24 (.363)
P7-M2-66-213-008	6.6 (.259)	2.13 (.084)	10.8 (.425)

Dimensions in millimeters (inch) unless otherwise stated

Other options available. For complete details on variety, part numbers, installation and specification, go to



[www.southco.com/P7](http://www.southco.com/P7)

**southco**  
CONNECT · CREATE · INNOVATE