

Southco® Compression Latches

Flush T-handle Series, Adjustable-grip Style

- Turn handle 90° to latch or unlatch
- T-handle folds away
- An extra turn adjusts the amount of compression applied

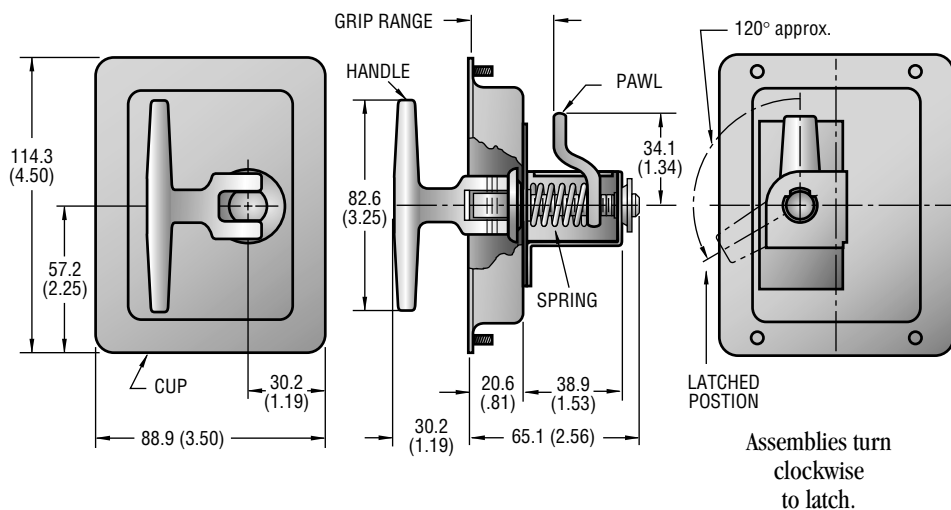

Material and Finish

For all models

PAWL: Steel, zinc plate, chromate, plus sealer. WASHER: Steel. RETAINER: 1010 Steel. BUSHING: Low carbon steel. MOUNTING NUTS and LOCKWASHERS: Steel. Components listed above are zinc plated plus chromate dip. PAWL SPRING: 304 Stainless steel, passivated. GROOVE PIN: 1112 Steel, zinc plate, chromate plus sealer. CONICAL SPRING: Spring wire, zinc plate, chromate plus sealer.

For assemblies with a stainless steel cup
CUP and HOUSING: 304 Stainless steel, highly polished. MOUNTING STUDS: 302 or 305 Stainless steel, natural. SCREW: Low carbon steel, HANDLE: Die-cast zinc; CUP WASHER: 1010 Steel; these components are chrome plated.

For assemblies with a steel cup
CUP, HOUSING, and CUP WASHER: 1010 Steel. MOUNTING STUDS: Steel. SCREW: Low carbon steel. HANDLE: Die-cast zinc. Components listed above are zinc immersion coated.

GRIP RANGE		PART NUMBERS	
		CUP and HOUSING: Polished stainless steel. HANDLE: Die cast zinc, chrome plated.	CUP and HOUSING: Steel, DACROTIZED†. HANDLE: Die cast zinc, DACROTIZED†.
MIN.	MAX.		
19.1 (.75)	37.3 (1.47)	24-20-101-35●	24-20-101-10●
31.8 (1.25)	50.2 (1.98)	24-20-102-35●	24-20-102-10
44.5 (1.75)	61.9 (2.44)	24-20-104-35●	24-20-104-10

Panel Preparation

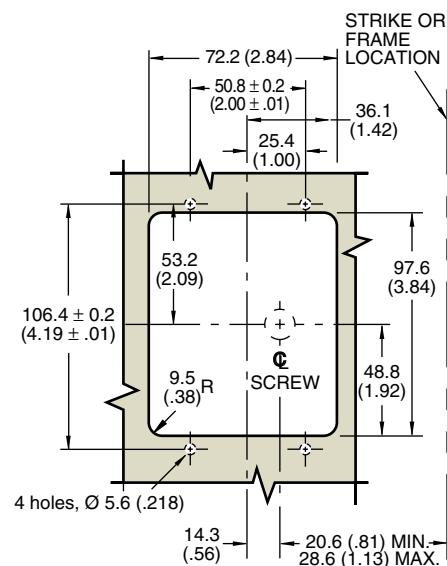

10-24 mounting nuts and lockwashers supplied

- 7.9 (.31) MAX. panel thickness
- Tightening torque of mounting nuts not to exceed 2.8 N•m or 25 in.-lbs.

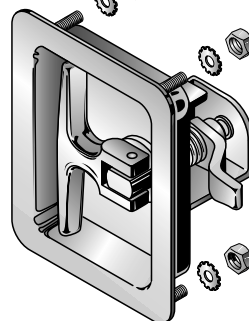

Product Strength Guidelines

(To assist in your product selection; samples are available for your evaluation.)

Force applied to pawl where it contacts frame.

Maximum static load: 1110 N (250 lbs.)

Average ultimate load: 1550 N (350 lbs.)

millimeter (inch)
millimeter
(inch)

Dimensions without tolerances are for reference only.