

# C2 Compression Latch

## Lever latch · Access indicator



106A

### Access Indicator

- Green** – Unaccessed
- Red** – Accessed (Operated)

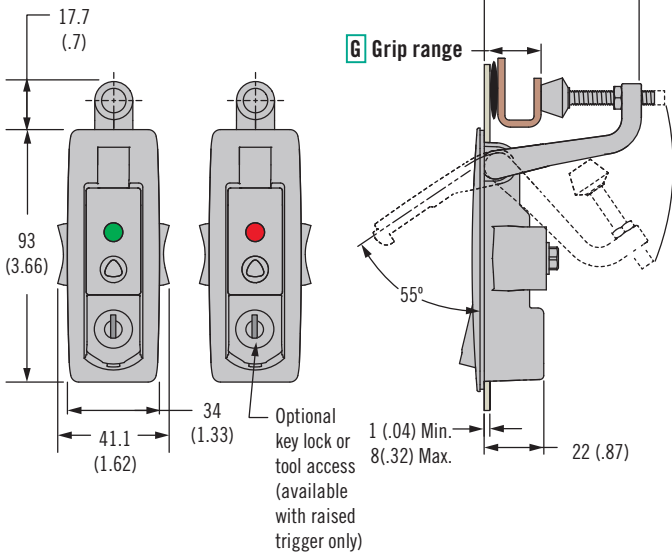

### Panel Preparation

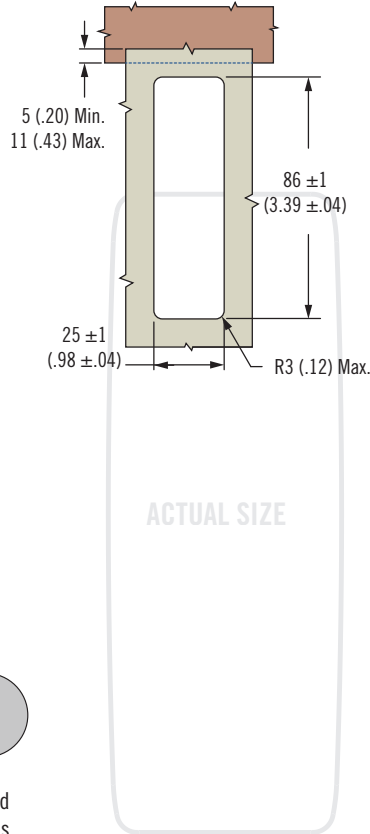

- Visual access status
- Easy grip adjustment
- Push button actuation
- Integrated bumper screw

### Material and Finish

Zinc alloy, powder coated or chrome plated and steel, zinc plated

### Performance Details

Maximum static load: 200 N (45 lbf)

### Sealing Notes

NEMA 4 and IP65 enabled using supplied gasket.

### Installation Notes

\* For door thickness greater than 5 (.20) calculate screw length using the following formula:  
Door thickness + 12 (.47)

### Indicator Reset Key

Part number: C2-26-301-05

### L Lock Styles



### Part Number Selection

See table

### Notes

For lock core selection and a complete overview of the **SOUTHCO**® Key-Choice System see [www.southco.com](http://www.southco.com)

### L Lock style

- Non-locking raised trigger
- Key-locking raised trigger keyed CH751 (two flat keys supplied)
- Flush trigger non-locking
- 4 (.16) Hex recess raised trigger
- No. 2 Phillips raised trigger
- Locking without lock core (see page 158 for lock core options)
- Railway standard

### F Finish

- Textured chrome
- Black powder coated

### P Packaging option

- Latches are sold layer packed. Omit for individually packaged latches.

C2 - A4 G - L F - P

G Grip Range	A	B
2	1 - 18 (.04 - .71)	35 (1.38) 65 (2.56)
3	17 - 39 (.67 - 1.53)	57 (2.24) 85 (3.35)