

D8 *DZUS*[®] PANEX Quarter-Turn Fasteners Receptacles · Size 4

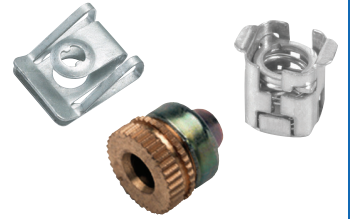

395

Clip-On

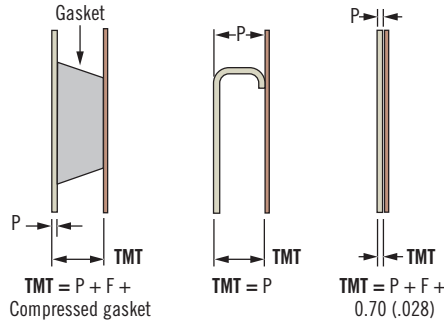
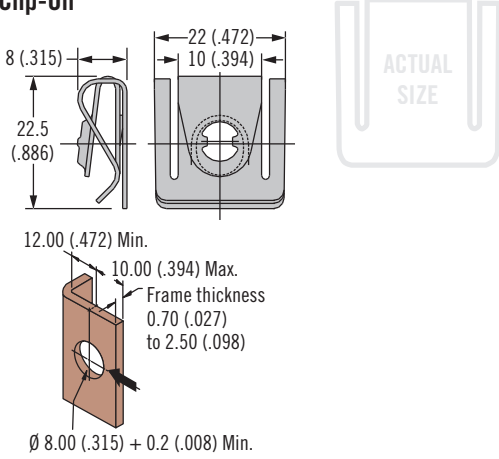

Part Number	Stud Selection Column
D8-334-300-121	B

Material and Finish

Steel, zinc immersion coating

Part Number

See table

Notes

Utilize stud selection column indicated when choosing a stud length from the stud length table on page 393

Front Mount Clip-In

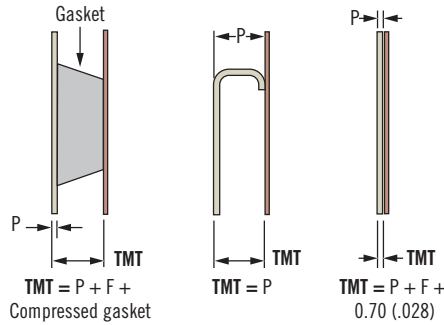
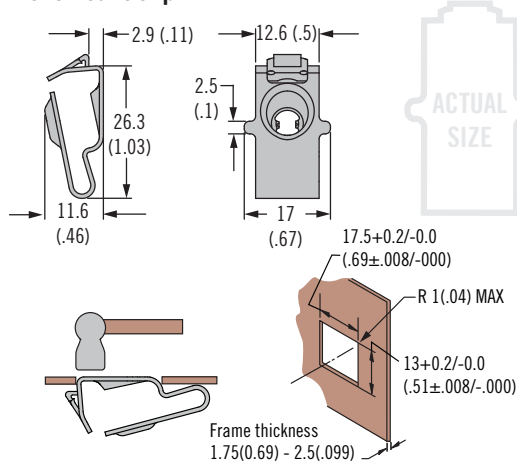

Part Number	Stud Selection Column
D8-334-700-121	B

Material and Finish

Steel, zinc immersion coating

Part Number

See table

Notes

Utilize stud selection column indicated when choosing a stud length from the stud length table on page 393

Front Mount Snap-In

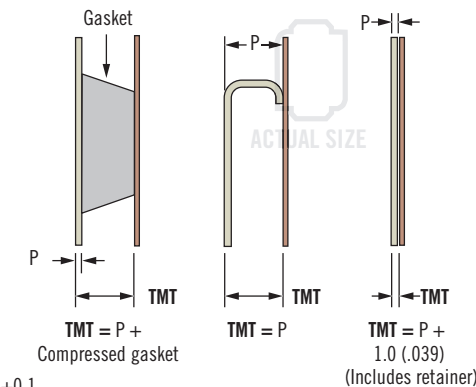
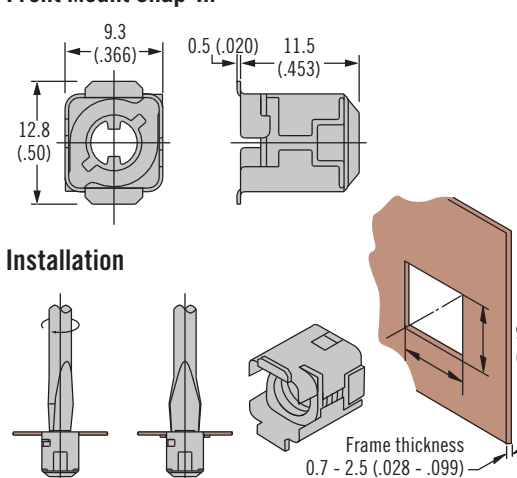

Part Number	Stud Selection Column
D8-334-200-190	C

Material and Finish

Steel, zinc plated and stainless steel

Part Number

See table

Notes

Utilize stud selection column indicated when choosing a stud length from the stud length table on page 393

D8 DZUS® PANEX Quarter-Turn Fasteners

Receptacles - Size 6

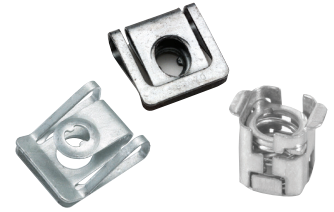

401

Clip-On

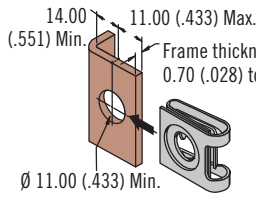
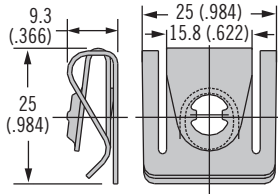

Clip-On - Mini

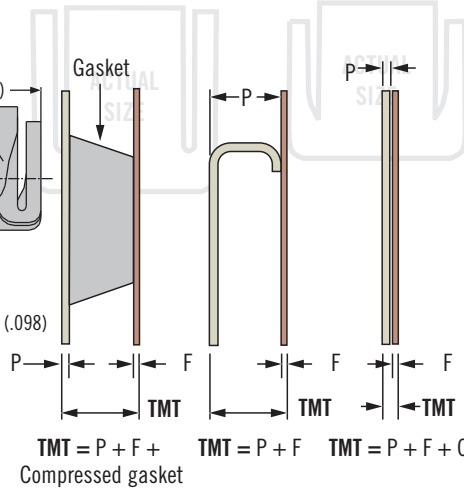
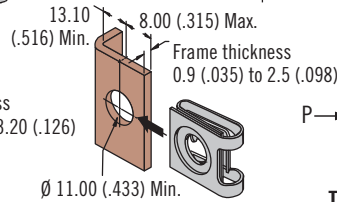
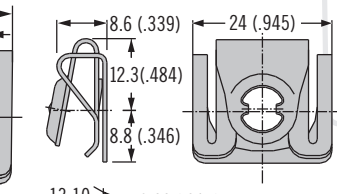

Style	Material	Part Number	C	Stud Selection Column
Clip-On	Steel	D8-336-330-121	0.8(0.031)	B
Clip-On-Mini	Steel	D8-336-330-200	0.7(0.028)	
Clip-On-Mini	Stainless steel	D8-336-330-200		

Material and Finish

Steel, zinc immersion coating

Part Number

See table

Notes

Utilize stud selection column indicated when choosing a stud length from the stud length table on page 399

Front Mount Clip-In

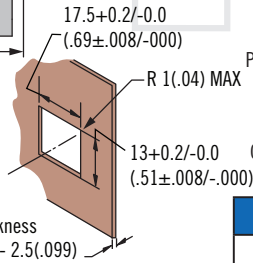
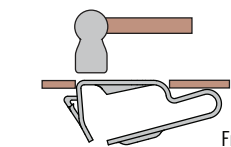
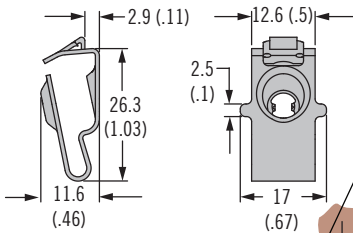

Frame thickness
1.75(0.69) - 2.5(.099)

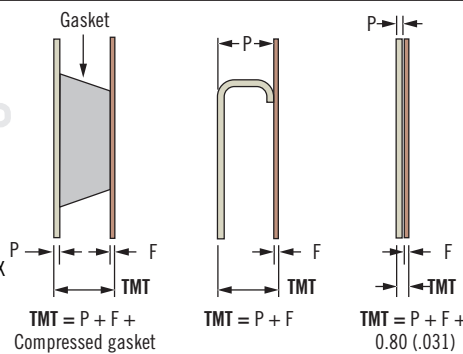

Part Number	Stud Selection Column
D8-336-700-121	B

Material and Finish

Steel, zinc immersion coating or stainless steel

Part Number

See table

Notes

Utilize stud selection column indicated when choosing a stud length from the stud length table on page 399

Front Mount Snap-In

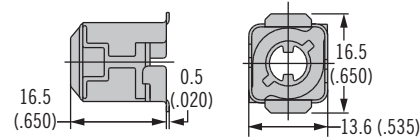

Installation

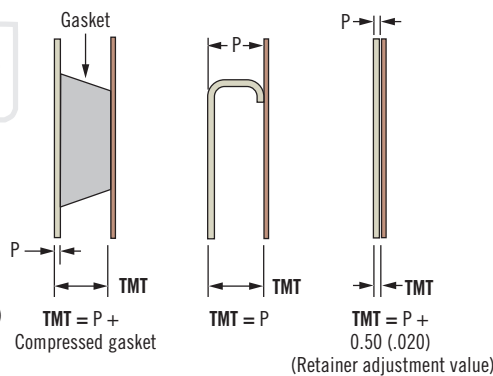
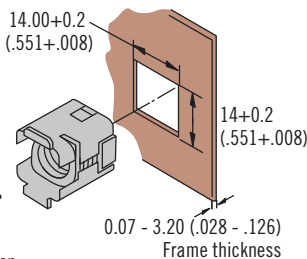
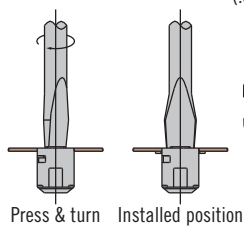

Part Number	Stud Selection Column
D8-336-200-190	C

Material and Finish

Steel, zinc plated and stainless steel

Part Number

See table

Notes

Utilize stud selection column indicated when choosing a stud length from the stud length table on page 399