



E5 Cam Latch

Zinc · Shutter · Tool operated · Fixed grip

- Single hole install
- Latched / unlatched detent
- Vibration resistant
- EN 61373 Compliant

Material and Finish

Zinc alloy, powder coated or chrome plated and steel, zinc plated

Performance Details

Maximum static load: 330 N (74 lbf)

Installation Notes

Mounting nut maximum tightening torque: 10 N·m (88 in·lbf)

Screw Maximum tightening torque: 5 N·m (45 in·lbf)

Sealing Notes

NEMA 4 / IP65 achieved using gasket supplied

Keys and Accessories

See page 130

Part Number Selection

See table

Order latch and cam separately

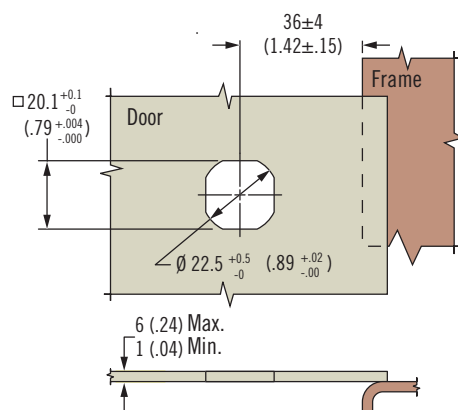
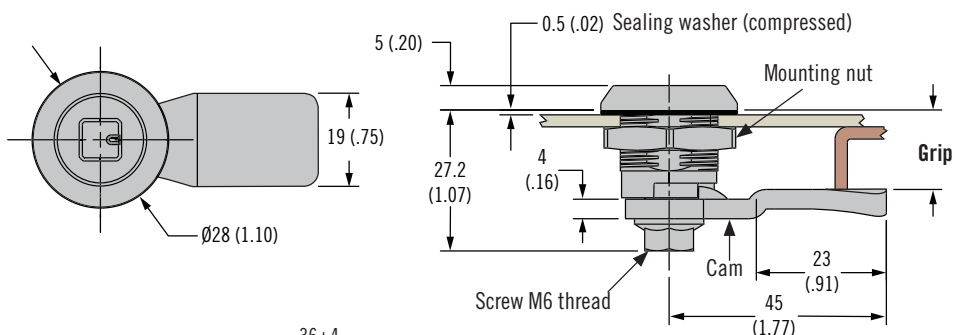

Insert key to depress shutter and rotate cam

H Head Styles



Latch Part Number (no cam)

E5 - 8 - H F - UU1

- F Finish**
- 2 Bright chrome
 - 5 Black powder coated

- H Head style**
- 02 7 (.28) Triangle
 - 03 8 (.32) Triangle
 - 04 7 (.28) Square
 - 05 8 (.32) Square
 - 13 Bellcore 216

Cam Part Number Table (order separately from latch)							
Grip	Part Number	Grip	Part Number	Grip	Part Number	Grip	Part Number
4 (.16)	E5-6003	14 (.55)	E5-6008	24 (.94)	E5-6013	34 (1.34)	E5-6018
6 (.24)	E5-6004	16 (.63)	E5-6009	26 (1.02)	E5-6014	36 (1.42)	E5-6019
8 (.31)	E5-6005	18 (.71)	E5-6010	28 (1.10)	E5-6015	38 (1.50)	E5-6020
10 (.39)	E5-6006	20 (.79)	E5-6011	30 (1.18)	E5-6016	40 (1.57)	E5-6021
12 (.47)	E5-6007	22 (.87)	E5-6012	32 (1.25)	E5-6017	42 (1.65)	E5-6022